

# Pioneer District Pinewood Derby Rules

## Length, Width and Clearance

- A. Maximum overall width (including wheels and axles) shall not exceed 2-3/4 inches.
- B. Minimum width between wheels shall be 1-3/4 inches so that car shall clear the center guide strip.
- C. Minimum clearance between bottom of car and track shall be 3/8 inches so that car shall clear the center guide strip on the plastic track.
- D. Maximum length shall not exceed 7 inches. No part of the car shall extend over the top of or in front of the starting peg on the racetrack.
- E. Maximum height shall not exceed 4 inches.
- F. Front of cars may be notched. However, the notch shall be a minimum of 1/2 inch wide. The notch shall be square and centered. No "V" notched or "W" notched front ends shall be allowed. (See: Front Notch Specifications)

## Weight and Appearance

- A. Weight shall not exceed five (5.000) ounces. The readings of the official race scale shall be considered final. The wooden car may be hollowed out and built up to the maximum weight by the addition of wood or metal or plastic; provided it is securely affixed to it. No loose materials of any kind are permitted in or on the car. Using tape to secure coins or washers to a car does not qualify as "securely affixed"; items secured in such a manner are prone to fall off the cars.
- B. Mercury and Lead shall not be used for adding weight. It is a potential health hazard.
- C. Details such as steering wheel, driver, spoiler, decal, painting and interior details are permissible as long as these details do not exceed the maximum length, width and weight specifications
- D. Paper hubcaps are not permitted. If a car has paper hubcaps the racer must remove the hubcaps before inspection.

## Wheels and Axles

- A. Only the official Cub Scout Grand Prix Pinewood Derby Kit #17006 wheels and axles that come in the kit can be used. Older version wheels are not permitted. Axles may be polished. Wheels may be lightly sanded to remove the mold projection of the tread. This light sanding of the outer edge of the wheel is the only wheel modification allowed. The tread surface of the wheel may be altered only to a flat surface that is parallel to the axle. Beveling, tapering, thin sanding, wafering or lathe-turning of the wheels is prohibited! Do not drill or rout out the inside hub of the wheel or drill holes in the spoke area or side-walls of the tires. Ready-made (internet) modified wheels are not allowed and will not pass the width or diameter inspection.
- B. Any type of wheel bearing, graphite pads, Teflon washers, steel washers or bushings is prohibited.
- C. The car shall not ride on any type of springs.
- D. The car shall be free-wheeling with no starting device or other propulsion.
- E. Insert axles only into the grooves provided on the wood block of the car. **Long wheelbase cars are not allowed.** No axle guards can be used on the bottom of the cars. The Inspectors must see the end of the axle nail in the groove. Do not cover the complete nail grooves with wood putty or a body skin. Again, the inspectors must see the complete end of each of the nails (last 3/8" of the nail point).
- F. No lathe-turned wheels or speed-axles are permitted.
- G. Drill presses with mandrel or hand-held variable speed drills with mandrel in vices may be used to lightly sand wheels and polish axles. The wheel diameter must not be less than 1.181".
- H. You may file a groove in your axles to reduce friction. You may taper the inside head of each nail with a file and polish it. You may true-up or straighten the axles. At inspection they must see the pointed end of each nail axles.

- I. The car must have four (4) wheels and axles; however, only three (3) wheels are required to make contact with the track. You may raise one wheel off the track surface. No wheel replacement fin allowed (Internet item).
- J. Do not reduce the width of the wheels. Must not be less than .361" in width.
- K. For examples of legal and illegal wheels, a legal tapered head axle and a diagram of a legal grooved axle (See: Wheel and Axle Specifications)

## Lubrication

- A. Only dry powder lubricants, such as graphite, may be used. Regular oils and silicone sprays are prohibited and may soften the plastic wheels and plastic race track. Cars found with liquid on axles will not be allowed to race.
- B. Cars may be lubricated in the Pit Area before inspection. No further lubrication shall be permitted.
- C. Cars may be lubricated before the final overall race between classification (by Cub Scout Rank) winners.

## Inspection and Disputes

- A. Each car must pass inspection by the Inspection Team before it may compete. The Inspection Team has the right to disqualify those cars which do not meet these rules. Car owners (racers) shall be informed of the violations and given an opportunity to modify the car to meet these rules. Any modifications must be made prior to the closing of classification registration.
- B. The Inspection Team usually consists of the following people: the weight inspector, the width, length and wheelbase inspector, the wheel and axle inspector and the Timekeeper. There may be more members of the team at the registration and inspection tables.
- C. Decisions by the Race Officials are final.
- D. Un-scout-like conduct by any participant or member of the audience shall be grounds for expulsion from the competition and/or the race area.

## Ground Rules



- A. All racers shall be registered Cub Scouts of the Pioneer District selected by their respective Pack to race in the Pioneer District Pinewood Derby. The racers must race their own car. No substitute racer is allowed.
- B. The car raced at the Pioneer District Derby shall be the same car raced at the Cub Scout's Pack Derby, or, if no derby was held, a car built between December of the prior year and May of the current year. Do not build a new car for the Pioneer District Derby. Cars raced at the Pioneer District Pinewood Derby the prior year are prohibited from racing again.
- C. The race will be conducted on a 3 lane, aluminum track with an electronic timer, according to classification. Electronic finish lines shall be used to declare race winners. Electronic finish line results are final.
- D. If the car leaves its lane and interferes with another car, the race shall be run again. Track officials shall be the only members to check the car for problems with the Cub Scout. If the same car leaves its lane a second time, it shall automatically lose the race.
- E. If a car jumps off the track, the race shall be run again. Track officials shall be the only members to check the car for problems with the Cub Scout. If the same car jumps off the track a second time, it shall automatically lose the race.
- F. If a car suffers a mechanical problem, such as the loss of an axle, a broken wheel, etc., and a repair can be accomplished in a reasonable time (5 minutes), the race shall be run again. If not, the car shall automatically lose the race. Cub Scouts may be assisted in making repairs by their Crew Chief. Track officials shall oversee all repairs.
- G. Only Track officials, Cub Scout racers shall be permitted into the registration and track area. This rule shall be strictly enforced. Track officials shall place all cars in the impound area and shall give the car to each Cub Scout when he is called to the starting line.

- H. Only one (1) car per Cub Scout may be entered and can only be raced in one classification. (Example: The same car cannot race in Tigers and Bears, or Wolves and Webelos, etc.) No substitute race cars shall be permitted.
- I. Trophies will be awarded to First, Second, Third place finishers of each classification. First and Second place winners of each classification shall race each other to determine the overall fastest car in the District. The winner of this event will receive the "Fastest Car in the Pioneer District Pinewood Derby" trophy.
- J. There shall be a 30 second time limit for each Cub Scout to set his car on the track to race. If a Cub Scout exceeds the time limit, the Track official shall remind him of this rule. If he continues to exceed this limit, the Track official will tell the Cub Scout to step down after 30 seconds.
- K. Each Pack may send multiple racers and each Den will be able to send 1st and 2nd place from each den from each pack.

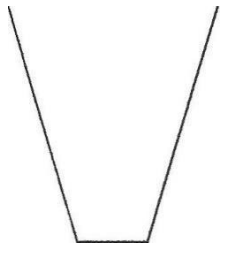
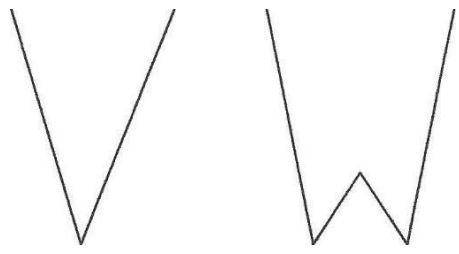
## Front Notch Specifications

Acceptable	Unacceptable
	
No less than ½ inch.	"V" Notch or "W" Notch

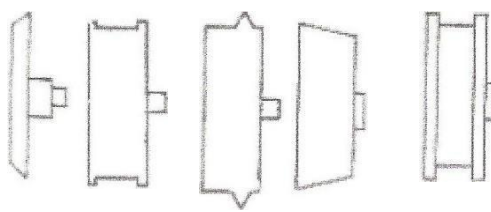
## Wheels and Axles Specifications

Prohibited Wheels	Permitted Tapered Head Axle
	

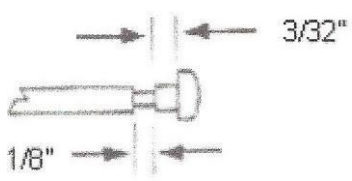
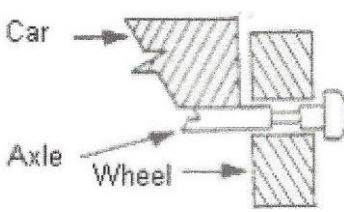
Permitted Grooved Axle	
	

## Pioneer District

This event is organized by the Pioneer District of the New Birth of Freedom Council. The Pioneer District serves Scouts within the Camp Hill, Carlisle, South Middleton, Mechanicsburg, Cumberland Valley, East Pennsboro, West Shore and Northern York County School Districts.

**Sal Franqui, District Director**

[sal.franqui@scouting.org](mailto:sal.franqui@scouting.org)

717-333-4846

**Justin Eberly, District Chair**

[justin.eberly@gmail.com](mailto:justin.eberly@gmail.com)

717-825-1763

**G.K. Cunningham, District Commissioner**

[gkc-nbofbsa@outlook.com](mailto:gkc-nbofbsa@outlook.com)

717-737-2231



## Point of Contact

**TBD, Event Chair**

email

phone

## Sign Up for the Pioneer District Newsletter!

Stay updated with news and information from the Pioneer District, New Birth of Freedom Council, delivered straight to your inbox.

<https://newbirthoffreedom.org/districts/pioneer/>